

## DIN EN ISO 15614-1



ICS 25.160.10

Supersedes DIN EN 288-3,  
October 1997 edition.

Specification and qualification of welding procedures for metallic materials

**Welding procedure test**Part 1: Arc and gas welding of steels and arc welding of nickel and nickel alloys  
(ISO 15614-1 : 2004)

English version of DIN EN ISO 15614-1

Anforderung und Qualifizierung von Schweißverfahren für metallische Werkstoffe – Schweißverfahrensprüfung – Teil 1: Lichtbogen- und Gasschweißen von Stählen und Lichtbogenschweißen von Nickel und Nickellegierungen (ISO 15614-1 : 2004)

*A comma is used as the decimal marker.***National foreword**

This standard has been published in accordance with a decision taken by CEN/TC 121 to adopt, without alteration, International Standard ISO 15614-1 as a European Standard.

The responsible German body involved in its preparation was the *Normenausschuss Schweißtechnik* (Welding Standards Committee), Technical Committee *Verfahrensprüfungen*.

DIN V 1738 is the standard corresponding to International Standard CR ISO 15608 referred to in clause 2 of the EN.

**Amendments**

This standard differs from DIN EN 288-3, October 1997 edition in that it has been revised in form and substance.

**Previous editions**

DIN 288-3: 1992-04, 1997-10.

**National Annex NA****Standard referred to**(and not included in **Normative references** and **Annex ZA**)

DIN V 1738 Welding – Guidelines for a metallic material grouping system (ISO/TR 15608 : 2000)

Document comprises 34 pages.

**English version**

Specification and qualification of welding procedures for metallic materials

**Welding procedure test**

Part 1: Arc and gas welding of steels and arc welding of nickel and nickel alloys  
(ISO 15614-1 : 2004)

Descriptif et qualification d'un mode opératoire de soudage pour les matériaux métalliques – Epreuve de qualification d'un mode opératoire de soudage – Partie 1: Soudage à l'arc et aux gaz des aciers et soudage à l'arc des nickels et alliages de nickel (ISO 15614-1 : 2004)

Anforderung und Qualifizierung von Schweißverfahren für metallische Werkstoffe – Schweißverfahrensprüfung – Teil 1: Lichtbogen- und Gas-schweißen von Stählen und Lichtbogenschiweißen von Nickel und Nickellegierungen (ISO 15614-1 : 2004)

This European Standard was approved by CEN on 2003-05-07.

CEN members are bound to comply with the CEN/CENELEC Internal Regulations which stipulate the conditions for giving this European Standard the status of a national standard without any alteration.

Up-to-date lists and bibliographical references concerning such national standards may be obtained on application to the Management Centre or to any CEN member.

The European Standards exist in three official versions (English, French, German). A version in any other language made by translation under the responsibility of a CEN member into its own language and notified to the Management Centre has the same status as the official versions.

CEN members are the national standards bodies of Austria, Belgium, Cyprus, the Czech Republic, Denmark, Estonia, Finland, France, Germany, Greece, Hungary, Iceland, Ireland, Italy, Latvia, Lithuania, Luxembourg, Malta, the Netherlands, Norway, Poland, Portugal, Slovakia, Slovenia, Spain, Sweden, Switzerland, and the United Kingdom.

**CEN**

European Committee for Standardization  
Comité Européen de Normalisation  
Europäisches Komitee für Normung

**Management Centre: rue de Stassart 36, B-1050 Brussels**

# Contents

	Page
Foreword.....	3
Introduction .....	4
1 Scope .....	4
2 Normative references .....	5
3 Terms and definitions.....	6
4 Preliminary welding procedure specification (pWPS) .....	6
5 Welding procedure test .....	6
6 Test piece.....	6
6.1 General.....	6
6.2 Shape and dimensions of test pieces.....	6
6.3 Welding of test pieces .....	7
7 Examination and testing .....	10
7.1 Extent of testing .....	10
7.2 Location and taking of test specimens.....	12
7.3 Non-destructive testing.....	16
7.4 Destructive testing.....	16
7.5 Acceptance levels .....	19
7.6 Re-testing.....	19
8 Range of qualification .....	20
8.1 General.....	20
8.2 Related to the manufacturer .....	20
8.3 Related to the parent material .....	20
8.4 Common to all welding procedures .....	24
8.5 Specific to processes .....	26
9 Welding procedure qualification record (WPQR) .....	27
Annex A (informative) Welding Procedure Qualification Record form (WPQR) .....	28
Annex ZA (normative) Corresponding International and European Standards for which equivalents are not given in the text .....	31
Annex ZB (informative) Clauses of this European Standard addressing essential requirements or other provisions of EU directives.....	32
Annex ZC (Informative) Clauses of this European Standard addressing essential requirements or other provisions of EU directives.....	33

## Foreword

This document has been prepared by Technical Committee CEN/TC 121 "Welding", the Secretariat of which is held by DIN, in collaboration with Technical Committee ISO/TC 44 "Welding and allied processes".

This European Standard shall be given the status of a national standard, either by publication of an identical text or by endorsement, at the latest by December 2004, and conflicting national standards shall be withdrawn at the latest by December 2004.

This document replaces EN 288-3:1992.

This document has been prepared under a mandate given to CEN by the European Commission and the European Free Trade Association, and supports essential requirements of EU Directive(s).

For relationship with EU Directive(s), see informative Annexes ZB and ZC.

According to the CEN/CENELEC Internal Regulations, the national standards organizations of the following countries are bound to implement this European Standard: Austria, Belgium, Cyprus, Czech Republic, Denmark, Estonia, Finland, France, Germany, Greece, Hungary, Iceland, Ireland, Italy, Latvia, Lithuania, Luxembourg, Malta, Netherlands, Norway, Poland, Portugal, Slovakia, Slovenia, Spain, Sweden, Switzerland and United Kingdom.

## Introduction

All new welding procedure tests are to be carried out in accordance with this standard from the date of its issue.

However, this European Standard does not invalidate previous welding procedure tests made to former national standards or specifications or previous issues of this standard.

Where additional tests have to be carried out to make the qualification technically equivalent, it is only necessary to do the additional tests on a test piece which should be made in accordance with this standard.

## 1 Scope

This European Standard is part of a series of standards, details of this series are given in EN ISO 15607:2003, annex A.

This standard specifies how a preliminary welding procedure specification is qualified by welding procedure tests.

This standard defines the conditions for the execution of welding procedure tests and the range of qualification for welding procedures for all practical welding operations within the range of variables listed in clause 8.

Tests shall be carried out in accordance with this standard. Additional tests may be required by application standards.

This standard applies to the arc and gas welding of steels in all product forms and the arc welding of nickel and nickel alloys in all product forms

Arc and gas welding are covered by the following processes in accordance with EN ISO 4063:

111 - manual metal arc welding (metal-arc welding with covered electrode);

114 - self-shielded tubular-cored arc welding;

12 - submerged arc welding;

131 - metal inert gas welding, MIG welding;

135 - metal active gas welding, MAG welding;

136 - tubular-cored metal arc welding with active gas shield;

137 - tubular-cored metal arc welding with inert gas shield;

141 - tungsten inert gas arc welding; TIG welding;

15 - plasma arc welding;

311 - oxy-acetylene welding.

The principles of this European Standard may be applied to other fusion welding processes.

## 2 Normative references

This European Standard incorporates by dated or undated reference, provisions from other publications. These normative references are cited at the appropriate places in the text, and the publications are listed hereafter. For dated references, subsequent amendments to or revisions of any of these publications apply to this European Standard only when incorporated in it by amendment or revision. For undated references the latest edition of the publication referred to applies, including amendments (including amendments).

EN 287-1, *Qualification testing of welders - Fusion welding - Part 1: Steels*

EN 439, *Welding consumables – Shielding gases for arc welding and cutting.*

EN 571-1, *Non destructive testing – Penetrant testing – Part 1: General principles.*

EN 875, *Destructive tests on welds in metallic materials - Impact tests - Test specimen location, notch orientation and examination.*

EN 895, *Destructive tests on welds in metallic materials – Transverse tensile test.*

EN 910, *Destructive tests on welds in metallic materials – Bend tests.*

EN 970, *Non-destructive examination of fusion welds - Visual examination.*

EN 1011-1 *Welding –Recommendations for welding of metallic materials –Part 1: General guidance for arc welding*

EN 1043-1:1995, *Destructive tests on welds in metallic materials – Hardness testing – Part 1: Hardness test on arc welded joints.*

EN 1290, *Non-destructive examination of welds - Magnetic particle examination of welds.*

EN 1321, *Destructive tests on welds in metallic materials - Macroscopic and microscopic examination of welds.*

EN 1418, *Welding personnel - Approval testing of welding operators for fusion welding and resistance weld setters for fully mechanized and automatic welding of metallic materials.*

EN 1435, *Non destructive examination of welds – Radiographic examination of welded joints.*

EN 1714, *Non destructive examination of welds – Ultrasonic examination of welded joints.*

EN ISO 4063, *Welding and allied processes – Nomenclature of processes and reference numbers (ISO 4063:1998).*

EN ISO 6947, *Welds - Working positions - Definitions of angles of slope and rotation (ISO 6947:1993).*

EN ISO 9606-4, *Approval testing of welders – Fusion welding – Part 4: Nickel and nickel alloys. (ISO 9606-4:1999).*

EN 12062, *Non-destructive examination of welds - General rules for metallic materials.*

EN ISO 15607:2003, *Specification and qualification of welding procedures for metallic materials - General rules (ISO 15607:2003).*

CR ISO 15608:2000 , *Welding - Guidelines for a metallic material grouping system (ISO/TR 15608:2000).*

prEN ISO 15609-1, *Specification and approval of welding procedures for metallic materials – Welding procedure specification – Part 1: Arc welding (ISO/DIS 15609-1:2000).*

EN ISO 15609-2, *Specification and qualification of welding procedures for metallic materials – Welding procedure specification – Part 2: Gas welding (ISO 15609-2:2001).*

EN ISO 15613, *Specification and qualification of welding procedure for metallic materials – Qualification based on pre-production welding test (ISO 15613:2003).*

EN ISO 5817, *Fusion-welded joints in steel, nickel titanium and their alloys (beam welding excluded) - Quality levels for imperfections (ISO 5817:2003).*



### 3 Terms and definitions

For the purposes of this European Standard, the terms and definitions given in EN ISO 15607:2003 apply.

### 4 Preliminary welding procedure specification (pWPS)

The preliminary welding procedure specification shall be prepared in accordance with prEN ISO 15609-1 or EN ISO 15609-2.

### 5 Welding procedure test

The welding and testing of test pieces shall be in accordance with clauses 6 and 7.

The welder or welding operator who undertakes the welding procedure test satisfactorily in accordance with this standard is qualified for the appropriate range of qualification according to EN 287-1 or EN ISO 9606-4 or EN 1418, providing that the relevant testing requirements are met.

### 6 Test piece

#### 6.1 General

The welded joint to which the welding procedure will relate in production shall be represented by making a standardized test piece or pieces, as specified in 6.2. Where the production/joint geometry requirements do not represent the standardized test pieces as shown in this standard, the use of EN ISO 15613 shall be required.

#### 6.2 Shape and dimensions of test pieces

The length or number of test pieces shall be sufficient to allow all required tests to be carried out.

Additional test pieces, or longer test pieces than the minimum size, may be prepared in order to allow for extra and/or for re-testing specimens (see 7.6).

For all test pieces except branch connections (see Figure 4) and fillet welds (see Figure 3) the material thickness,  $t$ , shall be the same for both plates/pipes to be welded.

If required by the application standard, the direction of plate rolling shall be marked on the test piece when impact tests are required to be taken in the Heat Affected Zone (HAZ).

The thickness and/or pipe outside diameter of the test pieces shall be selected in accordance with 8.3.2.1 to 8.3.2.3.

The shape and minimum dimensions of the test piece shall be as follows:

##### 6.2.1 Butt joint in plate with full penetration

The test piece shall be prepared in accordance with Figure 1.

##### 6.2.2 Butt joint in pipe with full penetration

The test piece shall be prepared in accordance with Figure 2.

NOTE The word "pipe", alone or in combination, is used to mean "pipe", "tube" or "hollow section".

### **6.2.3 T-joint**

The test piece shall be prepared in accordance with Figure 3.

This may be used for fully penetrated butt welds or fillet welds.

### **6.2.4 Branch connection**

The test piece shall be prepared in accordance with Figure 4. The angle  $\alpha$  is the minimum to be used in production.

This may be used for fully penetrated joints (set-on or set-in or set-through joint) and for fillet welds.

## **6.3 Welding of test pieces**

Preparation and welding of test pieces shall be carried out in accordance with the pWPS, and under the general conditions of welding in production which they shall represent. Welding positions and limitations for the angle of slope and rotation of the test piece shall be in accordance with EN ISO 6947. If tack welds are to be fused into the final joint they shall be included in the test piece.

Welding and testing of the test pieces shall be witnessed by an examiner or an examining body.



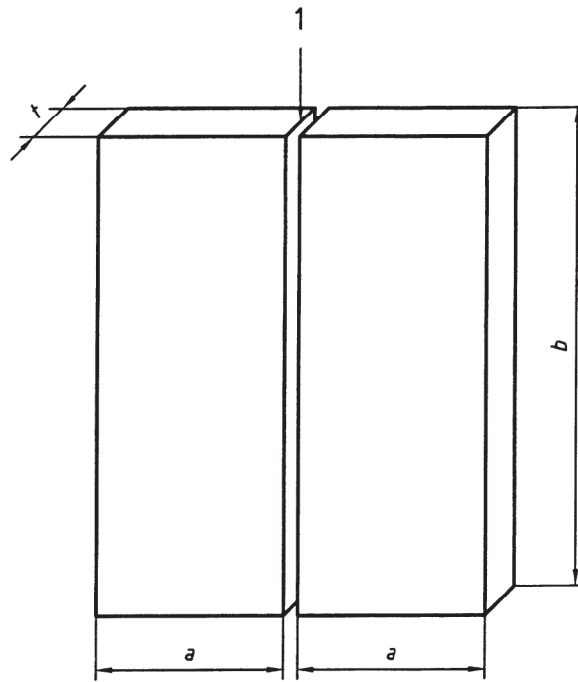

### Key

- 1 Joint preparation and fit-up as detailed in the preliminary Welding Procedure Specification (pWPS)
- $a$  Minimum value 150 mm
- $b$  Minimum value 350 mm
- $t$  Material thickness

**Figure 1 — Test piece for a butt joint in plate with full penetration**

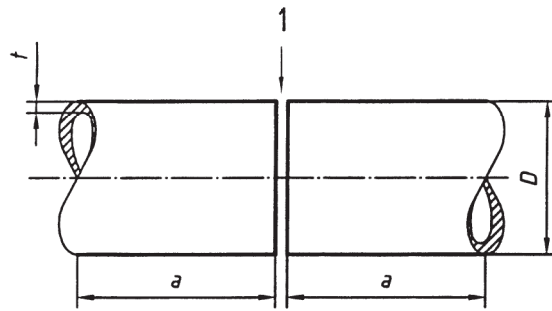

**Key**

- 1 Joint preparation and fit-up as detailed in the preliminary Welding Procedure Specification (pWPS)
- a* Minimum value 150 mm
- D* Outside pipe diameter
- t* Material thickness

**Figure 2 — Test piece for a butt joint in pipe with full penetration**

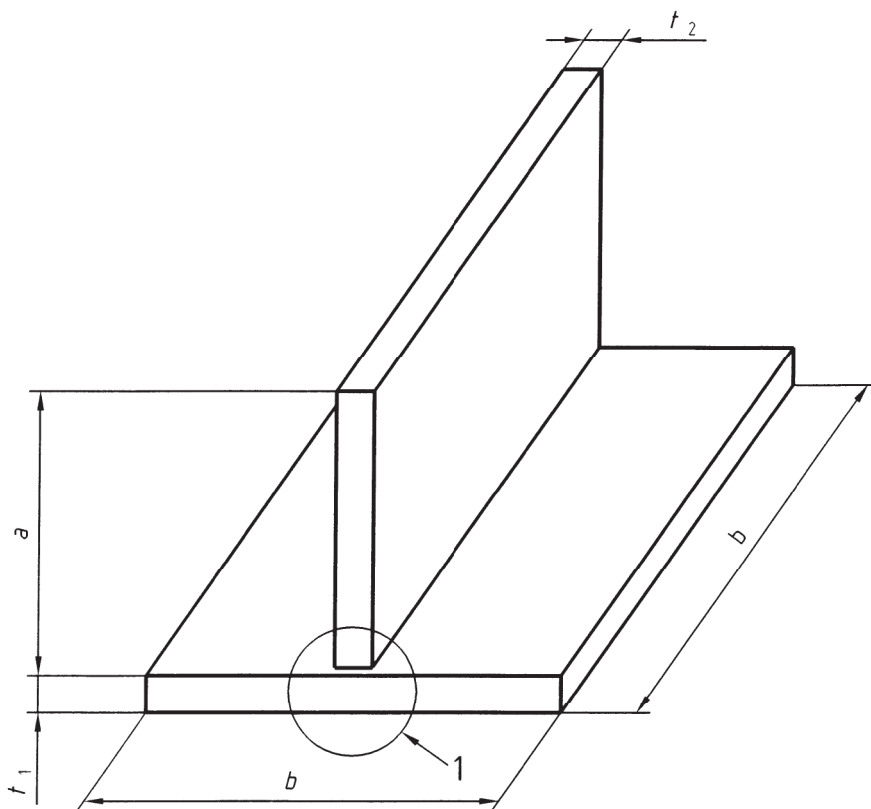

**Key**

- 1 Joint preparation and fit-up as detailed in the preliminary Welding Procedure Specification (pWPS)
- a* Minimum value 150 mm
- b* Minimum value 350 mm
- t* Material thickness

**Figure 3 — Test piece for a T-joint**

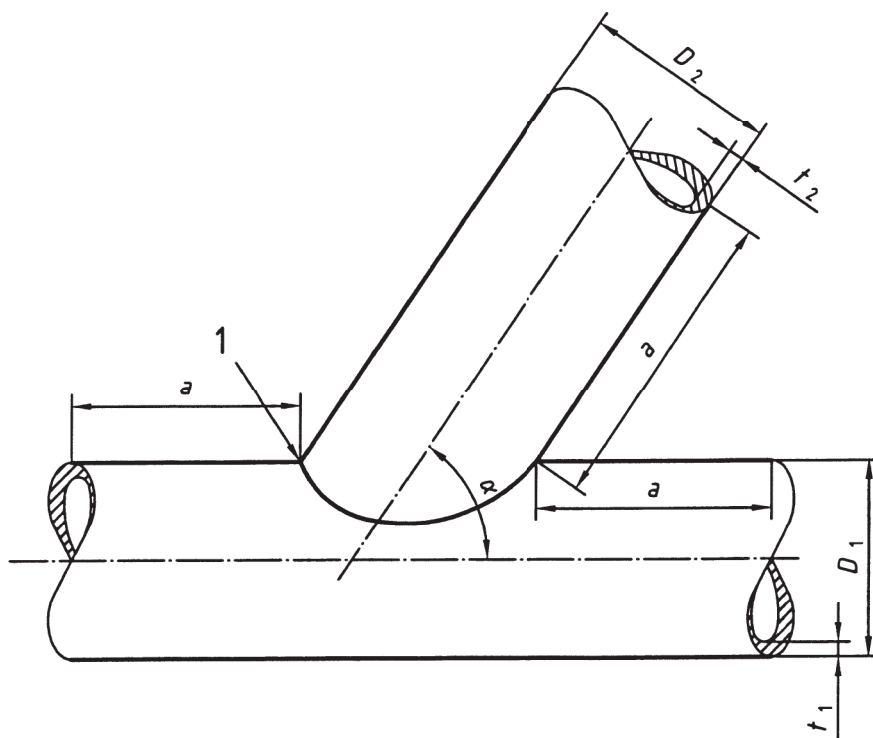

## Key

- 1 Joint preparation and fit-up as detailed in the preliminary Welding Procedure Specification (pWPS)
- $\alpha$  Branch angle
- $a$  Minimum value 150 mm
- $D_1$  Outside diameter of the main pipe
- $t_1$  Main pipe material thickness
- $D_2$  Outside diameter of the pipe
- $t_2$  Branch pipe material thickness

Figure 4 — Test piece for a branch connection

## 7 Examination and testing

### 7.1 Extent of testing

Testing includes both non-destructive testing (NDT) and destructive testing which shall be in accordance with the requirements of Table 1.

An application standard may specify additional tests, e.g.:

- longitudinal weld tensile test;
- all weld metal bend test;
- corrosion tests;
- chemical analysis;

- micro examination;
- delta ferrite examination;
- cruciform test.

NOTE Specific service, material or manufacturing conditions may require more comprehensive testing than is specified by this standard in order to gain more information and to avoid repeating the welding procedure test at a later date just to obtain additional test data.

**Table 1 — Examination and testing of the test pieces**

Test piece	Type of test	Extent of testing	Footnote
Butt joint with full penetration - Figure 1 and Figure 2	Visual	100 %	-
	Radiographic or ultrasonic	100 %	a
	Surface crack detection	100 %	b
	Transverse tensile test	2 specimens	-
	Transverse bend test	4 specimens	c
	Impact test	2 sets	d
	Hardness test	required	e
	Macroscopic examination	1 specimen	-
T- joint with full penetration - Figure 3 Branch connection with full penetration - Figure 4	Visual	100 %	f
	Surface crack detection	100 %	b and f
	Ultrasonic or radiographic	100 %	a, f and g
	Hardness test	required	e and f
Fillet welds - Figure 3 and Figure 4	Visual	100 %	f
	Surface crack detection	100 %	b and f
	Hardness test	required	e and f
	Macroscopic examination	2 specimens	f

a Ultrasonic testing shall not be used for  $t < 8$  mm and not for material groups 8, 10, 41 to 48.

b Penetrant testing or magnetic particle testing. For non-magnetic materials, penetrant testing.

c For bend tests, see 7.4.3.

d 1 set in the weld metal and 1 set in the HAZ for materials  $\geq 12$  mm thick and having specified impact properties. Application standards may require impact testing below 12 mm thick. The testing temperature shall be chosen by the manufacturer with regard to the application or application standard but need not be lower than the parent metal specification. For additional tests see 7.4.5.

e Not required for parent metals: -sub-group 1.1, and groups 8, 41 to 48.

f Tests as detailed do not provide information on the mechanical properties of the joint. Where these properties are relevant to the application an additional qualification shall also be held e.g. a butt weld qualification.

g For outside diameter  $\leq 50$  mm no ultrasonic test is required.

For outside diameter  $> 50$  mm and where it is not technically possible to carry out ultrasonic examination, a radiographic examination shall be carried out provided that the joint configuration will allow meaningful results.

## 7.2 Location and taking of test specimens

Test specimens shall be taken in accordance with Figures, 5, 6, 7 and 8.

Test specimens shall be taken after all non-destructive testing (NDT) has been carried out and which has passed the relevant inspection criteria for the NDT method(s) used.

It is acceptable to take the test specimens from locations avoiding areas which have imperfections within the acceptance limits for the NDT method(s) used.

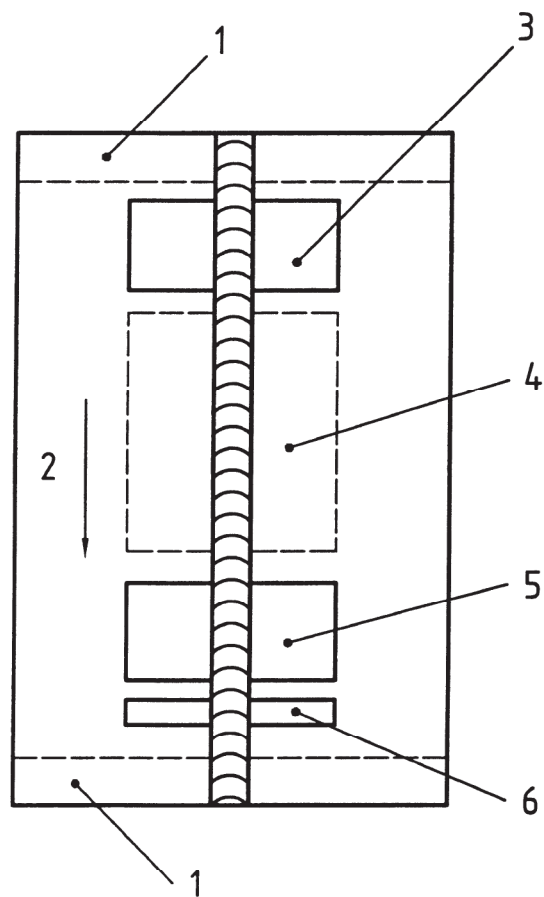

**Key**

- 1 Discard 25 mm
- 2 Welding direction
- 3 Area for:
  - 1 tensile test specimen;
  - bend test specimens.
- 4 Area for:
  - impact and additional test specimens if required.
- 5 Area for:
  - 1 tensile test specimen;
  - bend test specimens.
- 6 Area for:
  - 1 macro test specimen;
  - 1 hardness test specimen.

NOTE Not to scale.

**Figure 5 — Location of test specimens for a butt joint in plate**



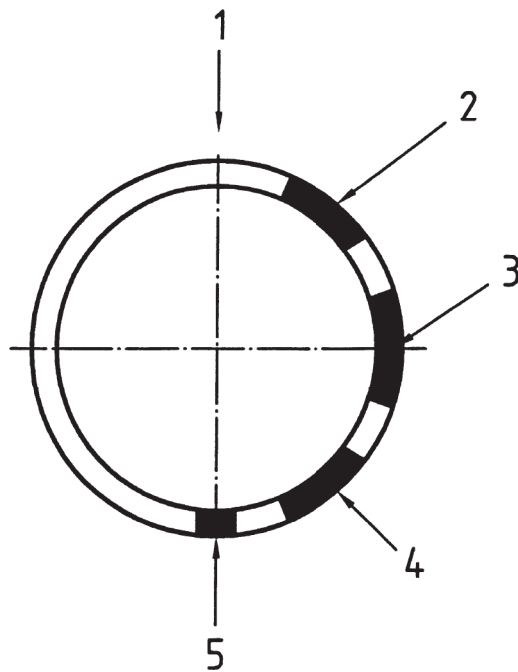

**Key**

- 1 Top of fixed pipe
- 2 Area for:
  - 1 tensile test specimen;
  - bend test specimens.
- 3 Area for:
  - impact and additional test specimens if required.
- 4 Area for:
  - 1 tensile test specimen;
  - bend test specimens.
- 5 Area for:
  - 1 macro test specimen;
  - 1 hardness test specimen.

NOTE Not to scale.

**Figure 6 — Location of test specimens for a butt joint in pipe**

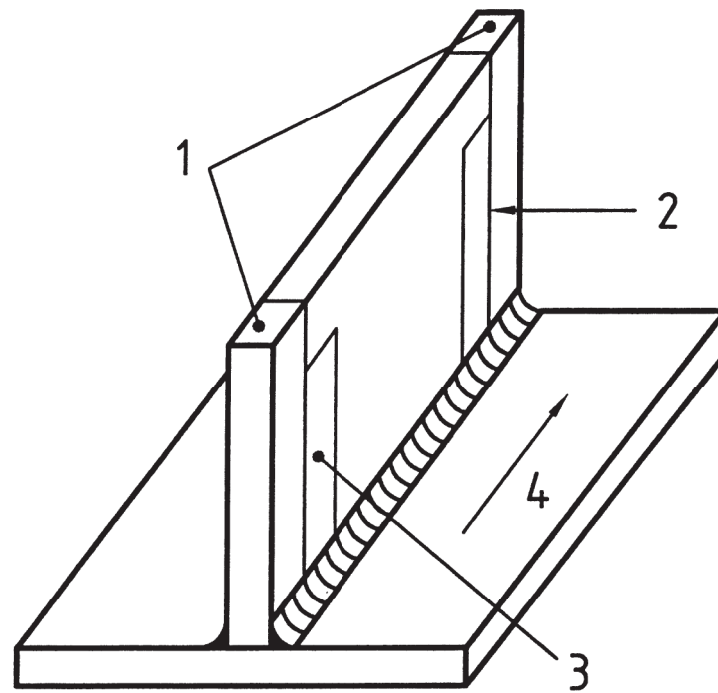

**Key**

- 1 Discard 25 mm
- 2 Macro test specimen
- 3 Macro and hardness test specimen
- 4 Welding direction

**Figure 7 — Location of test specimens in a T- joint**

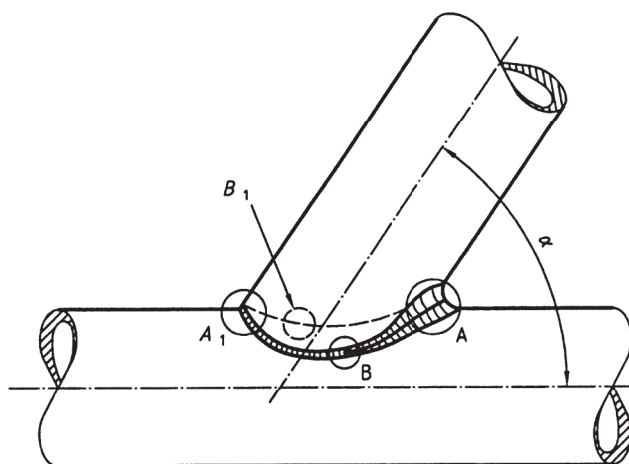

### Key

- 1 Macro and hardness test specimen to be taken (in position A)
- 2 Macro test specimen in position B

$\alpha$  = Branch angle

**Figure 8 — Location of test specimens for a branch connection or a fillet weld on pipe**

## 7.3 Non-destructive testing

All non-destructive testing in accordance with 7.1 and Table 1 shall be carried out on the test pieces prior to cutting of the test specimens. Any post-weld heat treatment that is specified shall be completed prior to non-destructive testing.

For materials that are susceptible to hydrogen induced cracking and where no post heating or no post-weld heat treatment is specified, non-destructive testing should be delayed.

Depending upon joint geometry, materials and the requirements for work, the NDT shall be carried out as required in Table 1 in accordance with EN 970 (visual examination), EN 1435 (radiographic testing), EN 1714 (ultrasonic testing), EN 571-1 (penetrant testing) and EN 1290 (magnetic particle testing).

## 7.4 Destructive testing

### 7.4.1 General

The extent of testing shall be as required by Table 1.

### 7.4.2 Transverse tensile test

Specimens and testing for transverse tensile testing for butt joint shall be in accordance with EN 895.

For pipes > 50 mm outside diameter, the excess weld metal shall be removed on both faces to give the test specimen a thickness equal to the wall thickness of the pipe.

For pipes  $\leq$  50 mm outside diameter, and when full section small diameter pipes are used, the excess weld metal may be left undressed on the inside surface of the pipe.

The tensile strength of the test specimen shall not be less than the corresponding specified minimum value for the parent metal unless otherwise specified prior to testing.

For dissimilar parent metal joints the tensile strength shall not to be less than the minimum value specified for the parent material having the lowest tensile strength.

### 7.4.3 Bend test

Specimens and testing for bend testing for butt joints shall be in accordance with EN 910.

For thicknesses < 12 mm two root and two face bend test specimens shall be tested. For thicknesses ≥ 12 mm four side bend specimens are recommended instead of root and face bend tests.

For dissimilar metal joints or heterogeneous butt joint in plates, one root and one face longitudinal bend test specimen may be used instead of four transverse bend tests.

The diameter of the former or the inner roller shall be  $4t$  and the bending angle shall be  $180^\circ$  for parent metal with elongation  $A \geq 20\%$ . For parent metal with elongation  $A < 20\%$  the following formula shall be applied:

$$d = \frac{(100 \times t_s)}{A} - t_s$$

where

$d$  is the diameter of the former or the inner roller

$t_s$  is the thickness of the bend test specimen

$A$  is the minimum tensile elongation required by the material specification

During testing, the test specimens shall not reveal any one single flaw > 3 mm in any direction. Flaws appearing at the corners of a test specimen during testing shall be ignored in the evaluation.

### 7.4.4 Macroscopic examination

The test specimen shall be prepared and etched in accordance with EN 1321 on one side to clearly reveal the fusion line, the HAZ and the build up of the runs.

The macroscopic-examination shall include unaffected parent metal and shall be recorded by at least one macro-reproduction per procedure test.

The acceptance levels shall be in accordance with 7.5.

### 7.4.5 Impact testing

Test specimens and testing for impact tests shall be in accordance with this standard for location of specimens and temperature of testing, and with EN 875 for dimensions and testing.

For weld metal, test specimen type VWT (V : Charpy V-notch - W : notch in weld metal - T : notch through the thickness) and for HAZ specimen type VHT (V : Charpy V-notch - H : notch in heat affected zone - T : notch through the thickness) shall be used. From each specified location, each set shall be comprised of three specimens.

Specimens with Charpy V-notch shall be used and sampled from a maximum of 2 mm below the surface of the parent metal and transverse to the weld.

In the HAZ the notch shall be at 1 mm to 2 mm from the fusion line and in the weld metal the notch shall be at the weld centreline.

For thicknesses > 50 mm, two additional sets of specimens shall be taken, one from the weld metal and one from the HAZ at the mid thickness or in the root area of the weld.

The absorbed energy shall be in accordance with the appropriate parent material standard unless modified by the application standard. The average value of the three specimens shall meet the specified requirements. For each notch location one individual value may be below the minimum average value specified, provided that it is not less than 70 % of that value.

For dissimilar metal joints impact tests shall be carried out on specimens from each HAZ in each parent metal.

Where multiple welding processes are qualified in a single test piece, impact test specimens shall be taken from the weld metal and HAZ that include each process.

#### **7.4.6 Hardness testing**

Vickers hardness testing with a load of HV10 shall be performed in accordance with EN 1043-1. Hardness measurements shall be taken in the weld, the heat affected zones and the parent metal in order to evaluate the range of hardness values across the welded joint. For material thicknesses less than or equal to 5 mm, only one row of indentations shall be made at a depth of up to 2 mm below the upper surface of the welded joint. For material thicknesses over 5 mm, two rows of indentations shall be made at a depth of up to 2 mm below the upper and lower surfaces of the of the welded joint. For double sided welds, fillet and T-butt welds, one additional row of indentations shall be made through the root area. Examples of typical indentation patterns are shown in Figures 1 a), b), e) and f) of EN 1043-1:1995 and Figures 3 and 4.

For each row of indentation at least 3 individual indentations in each of the following areas:

- the weld;
- both heat affected zones;
- both parent metals.

For the HAZ the first indentation shall be placed as close to the fusion line as possible.

The results from the hardness test shall meet the requirements given in Table 2. However requirements for Groups 6 (non heat treated), 7, 10 and 11 and any dissimilar metal joints shall be specified prior to testing.

**Table 2 — Permitted maximum hardness values (HV 10)**

<b>Steel groups CR ISO 15608</b>	<b>Non-heat treated</b>	<b>Heat treated</b>
1 <sup>a</sup> , 2	380	320
3 <sup>b</sup>	450	380
4,5	380	320
6	-	350
9.1	350	300
9.2	450	350
9.3	450	350
<p><sup>a</sup> If hardness tests are required.</p> <p><sup>b</sup> For steels with min <math>R_{eH} &gt; 890 \text{ N/mm}^2</math> special values shall be specified.</p>		

## 7.5 Acceptance levels

A welding procedure is qualified if the imperfections in the test piece are within the specified limits of quality level B in EN ISO 5817 except for imperfection types as follows: excess weld metal, excess convexity, excess throat thickness and excessive penetration, for which level C shall apply.

NOTE The correlation between the quality levels of EN ISO 5817 and the acceptance levels of the different NDT techniques are given in EN 12062.

## 7.6 Re-testing

If the test piece fails to comply with any of the requirements for visual examination or NDT specified in 7.5, one further test piece shall be welded and subjected to the same examination. If this additional test piece does not comply with the requirements, the welding procedure test has failed.

If any test specimens fail to comply with the requirements for destructive testing in accordance with 7.4 but only due to weld imperfections, two further test specimens shall be tested for each one that failed. The additional test specimens can be taken from the same test piece if there is sufficient material or from a new test piece. Each additional test specimen shall be subjected to the same tests as the initial test specimen that failed. If either of the additional test specimens does not comply with the requirements, the welding procedure test has failed.

If a tensile test specimen fails to meet the requirements of 7.4.2, two further test specimens shall be obtained for each one that failed. Both shall satisfy the requirements of 7.4.2.

If there are single hardness values in different test zones above the values indicated in Table 2 additional hardness tests may be carried out (on the reverse of the specimen or after sufficient grinding of the tested surfaces). None of the additional hardness values shall exceed the maximum hardness values given in Table 2.

For Charpy impacts tests, where the results from a set of three specimens do not comply with the requirements, with only one lower value below 70 %, three additional specimens shall be taken. The average value of these specimens together with the initial results shall not be lower than the required average.



## 8 Range of qualification

### 8.1 General

Each of the conditions given in clause 7 shall be met in order to comply with this standard.

Changes outside of the ranges specified shall require a new welding procedure test.

### 8.2 Related to the manufacturer

A qualification of a pWPS by a welding procedure test according to this standard obtained by a manufacturer is valid for welding in workshops or sites under the same technical and quality control of the manufacturer.

Welding is under the same technical and quality control when the manufacturer who performed the welding procedure test retains complete responsibility for all welding carried out to it.

### 8.3 Related to the parent material

#### 8.3.1 Parent material grouping

In order to minimise the number of welding procedure tests, steels, nickel and nickel alloys are grouped according to CR ISO 15608.

Separate welding procedure qualifications are required for each parent material or parent material combinations not covered by the grouping system.

If one parent material belongs to two groups or sub-groups, it shall always be classified in the lower group or sub-group.

NOTE Minor compositional differences between similar grades arising from the use of national standards do not need requalification

##### 8.3.1.1 Steels

The ranges of qualification are given in Table 3.

##### 8.3.1.2 Nickel alloys

The ranges of qualification are given in Table 4.

##### 8.3.1.3 Dissimilar joints between steels and nickel alloys

The ranges of qualification are given in Table 4.

**Table 3 — Range of qualification for steel groups and sub-groups**

Material (sub-) group of test piece	Range of qualification
1 - 1	1 <sup>a</sup> - 1
2 - 2	2 <sup>a</sup> - 2, 1 - 1, 2 <sup>a</sup> - 1
3 - 3	3 <sup>a</sup> - 3, 1 - 1, 2 - 1, 2 - 2, 3 <sup>a</sup> - 1, 3 <sup>a</sup> - 2
4 - 4	4 <sup>b</sup> - 4, 4 <sup>b</sup> - 1, 4 <sup>b</sup> - 2
5 - 5	5 <sup>b</sup> - 5, 5 <sup>b</sup> - 1, 5 <sup>b</sup> - 2
6 - 6	6 <sup>b</sup> - 6, 6 <sup>b</sup> - 1, 6 <sup>b</sup> - 2
7 - 7	7 <sup>c</sup> - 7
7 - 3	7 <sup>c</sup> - 3, 7 <sup>c</sup> - 1, 7 <sup>c</sup> - 2
7 - 2	7 <sup>c</sup> - 2 <sup>a</sup> , 7 <sup>c</sup> - 1
8 - 8	8 <sup>c</sup> - 8
8 - 6	8 <sup>c</sup> - 6 <sup>b</sup> , 8 <sup>c</sup> - 1, 8 <sup>c</sup> - 2, 8 <sup>c</sup> - 4
8 - 5	8 <sup>c</sup> - 5 <sup>b</sup> , 8 <sup>c</sup> - 1, 8 <sup>c</sup> - 2, 8 <sup>c</sup> - 4, 8 <sup>c</sup> - 6.1, 8 <sup>c</sup> - 6.2
8 - 3	8 <sup>c</sup> - 3 <sup>a</sup> , 8 <sup>c</sup> - 1, 8 <sup>c</sup> - 2
8 - 2	8 <sup>c</sup> - 2 <sup>a</sup> , 8 <sup>c</sup> - 1
9 - 9	9 <sup>b</sup> - 9
10 - 10	10 <sup>b</sup> - 10
10 - 8	10 <sup>b</sup> - 8 <sup>c</sup>
10 - 6	10 <sup>b</sup> - 6 <sup>b</sup> , 10 <sup>b</sup> - 1, 10 <sup>b</sup> - 2, 10 <sup>b</sup> - 4
10 - 5	10 <sup>b</sup> - 5 <sup>b</sup> , 10 <sup>b</sup> - 1, 10 <sup>b</sup> - 2, 10 <sup>b</sup> - 4, 10 <sup>b</sup> - 6.1, 10 <sup>b</sup> - 6.2
10 - 3	10 <sup>b</sup> - 3 <sup>a</sup> , 10 <sup>b</sup> - 1, 10 <sup>b</sup> - 2
10 - 2	10 <sup>b</sup> - 2 <sup>a</sup> , 10 <sup>b</sup> - 1
11 - 11	11 <sup>b</sup> - 11, 11 <sup>b</sup> - 1
a	Covers the equal or lower specified yield strength steels of the same group
b	Covers steels in the same sub-group and any lower sub-group within the same group
c	Covers steels in the same sub-group

**Table 4 — Range of qualification for nickel alloy and nickel alloy/steel groups**

Material group of the test pieces	Range of qualification
41 - 41	41 <sup>c</sup> - 41
42 - 42	42 <sup>c</sup> - 42
43 - 43	43 <sup>c</sup> - 43, 45 <sup>c</sup> - 45, 47 <sup>c</sup> - 47
44 - 44	44 <sup>c</sup> - 44
45 - 45	45 <sup>c</sup> - 45, 43 <sup>c</sup> - 43 <sup>c</sup>
46 - 46	46 <sup>c</sup> - 46
47 - 47	47 <sup>c</sup> - 47, 43 <sup>c</sup> - 43 <sup>c</sup> , 45 <sup>c</sup> - 45 <sup>c</sup>
48 - 48	48 <sup>c</sup> - 48
41 to 48 - 2	41 to 48 <sup>c</sup> - 2 <sup>a</sup> , 41 to 48 <sup>c</sup> - 1
41 to 48 - 3	41 to 48 <sup>c</sup> - 3 <sup>a</sup> , 41 to 48 <sup>c</sup> - 2 or 1
41 to 48 - 5	41 to 48 <sup>c</sup> - 5 <sup>b</sup> , 41 to 48 <sup>c</sup> - 6.2 or 6.1 or 4 or 2 or 1
41 to 48 - - 6	41 to 48 <sup>b</sup> - 6 <sup>b</sup> , 41 to 48 <sup>c</sup> - 4 or 2 or 1
NOTE: For groups 41 to 48, a procedure test carried out with a precipitation hardenable alloy in a group covers all precipitation hardenable alloys in that group welded to all solid solution alloys in the same group.	
<p>a Covers the equal or lower specified yield strength steels of the same group</p> <p>b Covers steels in the same sub-group and any lower sub-group within the same group</p> <p>c For groups 41 to 48, a procedure test carried out with a solid solution or precipitation hardenable alloy in a group covers all solid solution or precipitation hardenable alloys respectively in the same group.</p>	

### 8.3.2 Material thickness and pipe diameter

#### 8.3.2.1 General

— For single process qualification, the thickness,  $t$ , shall have the following meanings:

a) For a butt joint:

the parent material thickness.

b) For a fillet weld:

the parent material thicknesses. For each thickness range qualified as in Table 6 there is also an associated range of qualification for throat thicknesses,  $a$ , for single run fillet welds as given in 8.3.2.2.

c) For a set-on branch connection:

the parent material thicknesses.

d) For a set-in or set-through branch connection:

the parent material thicknesses.

e) For a T joint in plate with full penetration:

the parent material thickness.

— For multi-process qualification, the recorded thickness contribution of each process shall be used as a basis for the range of qualification for the individual welding process.

### 8.3.2.2 Range of qualification for butt joints, T- joints, branch connections and fillet welds

The qualification of a welding procedure test on thickness  $t$  shall include qualification for thickness in the following ranges given in Table 5 and Table 6.

For branch connections and fillet welds, the range of qualification shall be applied to both parent materials independently. When fillet weld is qualified by butt weld, table 6 applies.

**Table 5 — Range of qualification for butt welds material thickness and weld deposit thickness**

Dimensions in millimetres

Thickness of test piece $t$	Range of qualification	
	Single run	Multi-run
$t \leq 3$	0,7t to 1,3t	0,7t to 2t
$3 < t \leq 12$	0,5t (3 min.) to 1,3t <sup>a</sup>	3 to 2t <sup>a</sup>
$12 < t \leq 100$	0,5t to 1,1t	0,5t to 2t
$t > 100$	Not applicable	50 to 2t

<sup>a</sup> when impact requirements are specified the upper limit of qualification is 12 mm unless impact testing has been performed.

**Table 6 – Range of qualification for material thickness and throat thickness of fillet welds**

Dimensions in millimetres

Thickness of test piece $t$	Range of qualification		
	material thickness	Throat thickness	
		Single run	Multi-run
$t \leq 3$	0,7 t to 2 t	0,75 a to 1,5 a	No restriction
$3 < t < 30$	0,5 t (3 min.) to 1,2 t	0,75 a to 1,5 a	No restriction
$t \geq 30$	$\geq 5$	a	No restriction

NOTE 1 a is the throat as used for the test piece

NOTE 2 Where a fillet weld is qualified by means of a butt weld test, the throat thickness range qualified shall be based on the thickness of the deposited metal.

a for special applications only. Each throat thickness has to be proofed separately by a welding procedure test.

### 8.3.2.3 Range of qualification for the diameter of pipes and branch connections

The qualification of a welding procedure test on diameter  $D$  shall include qualification for diameters in the following ranges given in Table 7.

Qualification given for plates also covers pipes when the outside diameter is  $> 500$  mm or when the diameter is  $> 150$  mm welded in the PA or PC rotated position.

**Table 7 — Range of qualification for pipe and branch connection diameters**

Dimensions in millimetres

Diameter of the test piece $D^a$ , mm	Range of qualification
$D \leq 25$	$0,5D$ to $2D$
$D > 25$	$\geq 0,5D$ (25 mm min)
NOTE For structural hollow section $D$ is the dimension of the smaller side.	
<sup>a</sup> $D$ is the outside diameter of the pipe or outside diameter of the branch pipe.	

### 8.3.3 Angle of branch connection

A welding procedure test carried out on a branch connection with angle  $\alpha$  shall qualify all branch angles  $\alpha_1$  in the range of  $\alpha \leq \alpha_1 \leq 90^\circ$ .

## 8.4 Common to all welding procedures

### 8.4.1 Welding processes

Each degree of mechanization shall be qualified independently (manual, partly mechanized, fully mechanized and automatic).

In the same way, it is not allowed to change the means of implementation (manual, mechanised or automated).

The qualification is only valid for the welding process(es) used in the welding procedure test.

For multi-process procedures the welding procedure qualification may be carried out with separate welding procedure tests for each welding process. It is also possible to make the welding procedure test as a multi-process procedure test. The qualification of such a test is only valid for the process sequence carried out during the multi-process procedure test.

NOTE It is not allowed to use a multi-process procedure test to qualify any single process unless the testing carried out on the process conforms to this standard.

### 8.4.2 Welding positions

Welding of a test in any one position (pipe or plate) qualifies for welding in all positions (pipe or plate) except for PG and J-L045 where a separate welding procedure test shall be required.

When impact and/or hardness requirements are specified impact tests shall be taken from the weld in the highest heat input position and hardness tests shall be taken from the weld in the lowest heat input position in order to qualify for all positions.

For example, butt welds in plate the highest heat input position is normally PF and the lowest PC. For fixed pipe welds the hardness tests shall be taken from the overhead welding position

When neither impact nor hardness requirements are specified, welding in any one position (pipe or plate) qualifies for welding in all positions (pipe or plate).

To satisfy both hardness and impact requirements two test pieces in different welding positions are required unless a single position qualification is required. Where qualification is required for all positions both test pieces shall be subjected to full visual examination and non-destructive testing.

For material of Group 10, the lowest and highest heat input positions shall be subjected to both impact and hardness testing.

NOTE Other destructive tests may be taken from either test piece. One of the test pieces may be reduced length.

### 8.4.3 Type of joint/weld

The range of qualification for the type of welded joints is as used in the welding procedure test subject to limitations given in other clauses (eg diameter, thickness) and additionally:

- a) Butt welds qualify full and partial penetration butt welds and fillet welds. Fillet weld tests shall be required where this is the predominant form of production welding.
- b) Butt joints in pipe also qualify branch connections with an angle  $\geq 60^\circ$ ;
- c) T joints butt welded only qualify T joints butt welded and fillet welds (see a);
- d) Welds made from one side without backing qualify welds made from both sides and welds with backing;
- e) Welds made with backing qualify welds made from both sides;
- f) Welds made from both sides without gouging qualify welds made from both sides with gouging;
- g) Fillet welding qualifies fillet welding only;
- h) It is not permitted to change a multi-run deposit into a single run (or single run on each side) or vice versa for a given process.

### 8.4.4 Filler material, designation

Filler materials cover other filler materials as long as they have equivalent mechanical properties, same type of covering core or flux, same nominal composition and the same or lower hydrogen content according to the designation in the appropriate European standard for the filler material concerned.

### 8.4.5 Filler material, make (manufacturer and trade name)

When impact testing is required, for processes 111, 114, 12, 136 and 137 the range of validity is restricted to the specific make used in the procedure test. It is permissible to change the specific make of filler material to another with the same compulsory part of the designation when an additional test piece is welded. This test piece shall be welded using the identical welding parameters as the original test and only weld metal impact test specimens shall be tested.

NOTE This provision does not apply to solid wire and rods with the same designation and nominal chemical compositions.

### 8.4.6 Filler material size

It is permitted to change the size of filler material providing that the requirements of 8.4.8 are satisfied.

### 8.4.7 Type of current

The qualification is given for the type of current (alternating current (AC), direct current (DC), pulsed current) and polarity used in the welding procedure test. For process 111, alternating current also qualifies direct current (both polarities) when impact testing is not required.



#### **8.4.8 Heat Input**

When impact requirements apply, the upper limit of heat input qualified is 25 % greater than that used in welding the test piece.

When hardness requirements apply, the lower limit of heat input qualified is 25 % lower than that used in welding the test piece.

Heat input is calculated in accordance with EN 1011-1.

If welding procedure tests have been performed at both a high and a low heat input level, then all intermediate heat inputs are also qualified.

#### **8.4.9 Preheat temperature**

When preheating is required the lower limit of qualification is the nominal preheat temperature applied at the start of the welding procedure test.

#### **8.4.10 Interpass temperature**

The upper limit of the qualification is the highest interpass temperature reached in the welding procedure test.

#### **8.4.11 Post-heating for hydrogen release**

The temperature and duration of post-heating for hydrogen release shall not be reduced. Post-heating shall not be omitted, but may be added.

#### **8.4.12 Post-weld heat-treatment**

Addition or deletion of post-weld heat-treatment is not permitted.

The temperature range validated is the holding temperature used in the welding procedure test  $\pm 20$  °C unless otherwise specified. Where required, heating rates, cooling rates and holding time shall be related to the product.

#### **8.4.13 Initial heat treatment**

A change in the initial heat treatment condition prior to the welding of precipitation hardenable materials is not permitted.

### **8.5 Specific to processes**

#### **8.5.1 Process 12**

**8.5.1.1** Each variant of process 12 (121 to 125) shall be qualified independently.

**8.5.1.2** The qualification given for the flux is restricted to the make and designation used in the welding procedure test.

#### **8.5.2 Processes 131, 135, 136 and 137**

**8.5.2.1** The qualification given to the shielding gas is restricted to the symbol of the gas according to EN 439. However, the content of CO<sub>2</sub> shall not exceed 10 % of that used to qualify the procedure test. Shielding gases not covered by EN 439 are restricted to the nominal composition used in the test.

**8.5.2.2** The qualification given is restricted to the wire system used in the welding procedure test (e.g. single-wire or multiple-wire system).

**8.5.2.3** For solid and metal cored wires, the qualification using short circuiting transfer (dip) qualifies only short circuiting transfer (dip). Qualification using spray or globular transfer qualifies both spray and globular transfer.

### 8.5.3 Process 141

**8.5.3.1** The qualification given to the shielding gas and backing gas is restricted to the symbol of the gas according to EN 439. Shielding gases not covered by EN 439 are restricted to the nominal composition used in the test.

**8.5.3.2** A weld procedure test made without a backing gas qualifies a welding procedure with backing gas.

**8.5.3.3** Welding with filler material does not qualify for welding without filler material or visa versa.

### 8.5.4 Process 15

**8.5.4.1** Qualification of the welding procedure is restricted to the plasma gas composition used in the welding procedure test.

**8.5.4.2** The qualification given to the shielding gas and backing gas is restricted to the symbol of the gas according to EN 439. Shielding gases not covered by EN 439 are restricted to the nominal composition qualified.

**8.5.4.3** Welding with filler material does not qualify for welding without filler material or visa versa.

### 8.5.5 Process 311

Welding with filler material does not qualify for welding without filler material or visa versa.

## 9 Welding procedure qualification record (WPQR)

The welding procedure qualification record (WPQR) is a statement of the results of assessing each test piece including re-tests. The relevant items listed for the WPS in the relevant part of prEN ISO 15609 shall be included, together with details of any features that would be rejectable by the requirements of clause 7. If no rejectable features or unacceptable test results are found, a WPQR detailing the welding procedure test piece results is qualified and shall be signed and dated by the examiner or the examining body.

A WPQR format shall be used to record details for the welding procedure and the test results, in order to facilitate uniform presentation and assessment of the data.

An example of WPQR format is shown in annex A.



## Record of weld test

Location :	Examiner or examining body :
Manufacturer's pWPS No:	Method of Preparation and Cleaning :
Manufacturer's WPQR No:	Parent Material Specification :
Manufacturer :	Material Thickness (mm) :
Welder's Name :	Outside Pipe Diameter (mm) :
Mode of Metal Transfer :	Welding Position :
Joint Type and Weld:	
Weld Preparation Details (Sketch)* :	

Joint Design	Welding Sequences

### Welding Details

Run	Welding Process	Size of Filler Material	Current A	Voltage V	Type of current/ Polarity	Wire Feed Speed	Travel Speed*	Heat input*	Metal transfer

Filler Material Designation and Make :  
 Any Special Baking or Drying :  
 Gas/Flux : shielding  
                   backing :  
 Gas Flow Rate – Shielding :  
                   Backing :  
 Tungsten Electrode Type/Size :  
 Details of Back Gouging/Backing :  
 Preheat Temperature :  
 Interpass Temperature :  
 Post-Heating :  
 Post-Weld Heat Treatment :  
 (Time, Temperature, Method :  
 Heating and Cooling Rates\*) :

Other information\* e.g.:  
 Weaving (maximum width of run) :  
 Oscillation : amplitude, frequency, dwell time  
 Pulse welding details :  
 Distance contact tube/ workpiece:  
 Plasma welding details :  
 Torch angle :

.....

Manufacturer  
 Name, date and signature  
 \* If required

.....

Examiner or examining body  
 Name, date and signature



## Annex ZA (normative)

### Corresponding International and European Standards for which equivalents are not given in the text

At the time of publication of this part of ISO 15614, the editions of the following documents were valid. Members of ISO and IEC maintain registers of currently valid International Standards.

EN 439	ISO 14175,	<i>Welding consumables — Shielding gases for arc welding and cutting.</i>
EN 571-1	ISO 3452-1	<i>Non-destructive testing — Penetrant testing — Part 1: General principles</i>
EN 875	ISO 9016,	<i>Destructive tests on welds in metallic materials — Impact tests — Test specimen location, notch orientation and examination.</i>
EN 895	ISO 4136,	<i>Destructive tests on welds in metallic materials — Transverse tensile test.</i>
EN 910	ISO 5173,	<i>Destructive tests on welds in metallic materials — Bend tests.</i>
EN 970	ISO 17637,	<i>Non destructive testing of welds — Visual testing of fusion-welded joints</i>
EN 1043-1	ISO 9015-1,	<i>Destructive tests on welds in metallic materials - Hardness testing — Part 1: Hardness test on arc welded joints.</i>
EN 1290	ISO 17638,	<i>Non destructive testing of welds — Magnetic particle testing.</i>
EN 1321	ISO 17639,	<i>Destructive tests on welds in metallic materials - Macroscopic and microscopic examination of welds.</i>
EN 1418	ISO 14732,	<i>Welding personnel. Approval testing of welding operators for fusion welding and of resistance weld setters for fully mechanized and automatic welding of metallic materials.</i>
EN 1435	ISO 17636,	<i>Non destructive testing of welds — Radiographic examination of fusion-welded joints.</i>
EN 1714	ISO 17640	<i>Non destructive examination of welds — Ultrasonic examination of welded joints.</i>
EN 12062	ISO 17635,	<i>Non-destructive testing of welds - General rules for fusion welds in  metallic materials.</i>



## **Annex ZB** (informative)

### **Clauses of this European Standard addressing essential requirements or other provisions of EU directives**

This European standard has been prepared under a mandate given to CEN by the European Commission and the European Free Trade Association to provide a means of conforming to Essential Requirements of the New Approach Directive 97/23/EC..

Once this standard is cited in the Official Journal of the European Communities under that Directive and has been implemented as a national standard in at least one Member State, compliance with the clauses of this standard given in table ZB confers, within the limits of the scope of this standard, a presumption of conformity with the corresponding Essential Requirements of that Directive and associated EFTA regulations.

**Table ZB – Correspondance between this European standard and the Directive 97/23/EC**

Clauses/Paragraphs of this European standard	Essential requirement of the Directive 97/23/EEC	Comments/Notes
All clauses	Annexe I, 3.1.2	Permanent joining

WARNING: Other requirements and other EU Directives may be applicable to the product(s) falling within the scope of this standard.

## Annex ZC (Informative)

### Clauses of this European Standard addressing essential requirements or other provisions of EU directives

This European standard has been prepared under a mandate given to CEN by the European Commission and the European Free Trade Association and supports essential requirements of EU Directive 87/404/EEC.

Compliance with the clauses of this standard provides one with means of conforming with the specific essential requirements of the Directive concerned and associated EFTA regulations.

**Table ZC – Relation between this European standard and the Directive 87/404/EEC**

Clauses/Paragraphs of this European standard	Essential requirement of the Directive 87/404/EEC	Comments/Notes
Clause 9, Annex A	Annex II, 3.c.iii	Welding Procedure Qualification Record

WARNING: Other requirements and other EU Directives may be applicable to the product(s) falling within the scope of this standard.